

Kleine, trocken laufende Drehschieber-Vakuumpumpen

Saugvermögen 3,5 bis 12 m³/h, max. Endvakuum 150 mbar (abs.).
 Kompakte, einbaufreundliche Bauart, besonders leiser Lauf, korrosionsgeschützter Rotor, serienmäßiger Schlauchanschluss und Ausblasschalldämpfer.
 Die Motoren entsprechen DIN EN 60034 und sind in Schutzart IP 55 und Isolationsklasse F ausgeführt.

Small, dry running rotary vane vacuum pumps

Capacities ranging from 3.5 to 12 m³/hr, ultimate vacuum 150 mbar (abs.).
 Compact design, easy to build into machines. Very low noise level. Corrosion proof rotors. Hose connection and exhaust silencer as standard.
 Motors correspond to DIN EN 60034 and have IP 55 protection and insulation class F.

Auswahldiagramm • Selection diagram 50 Hz

60 Hz

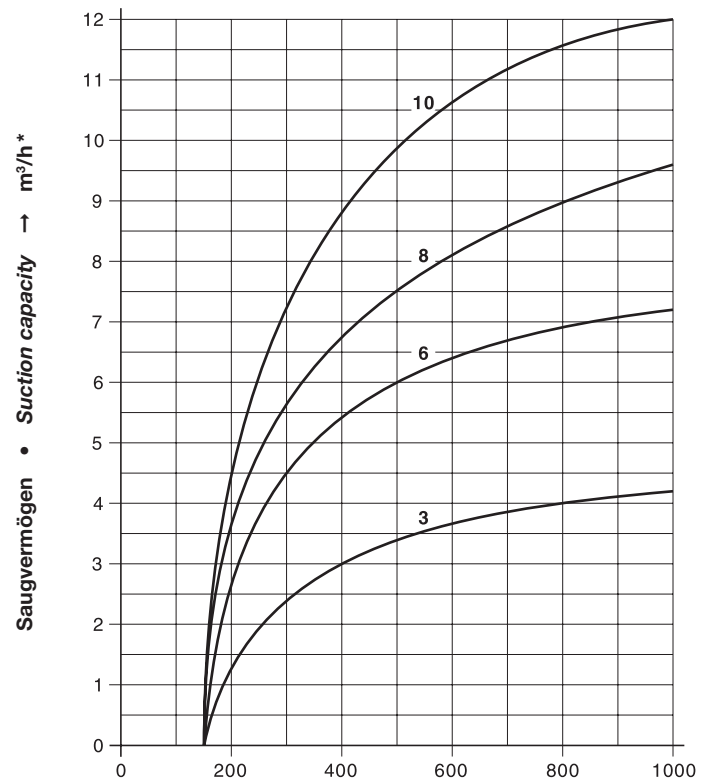
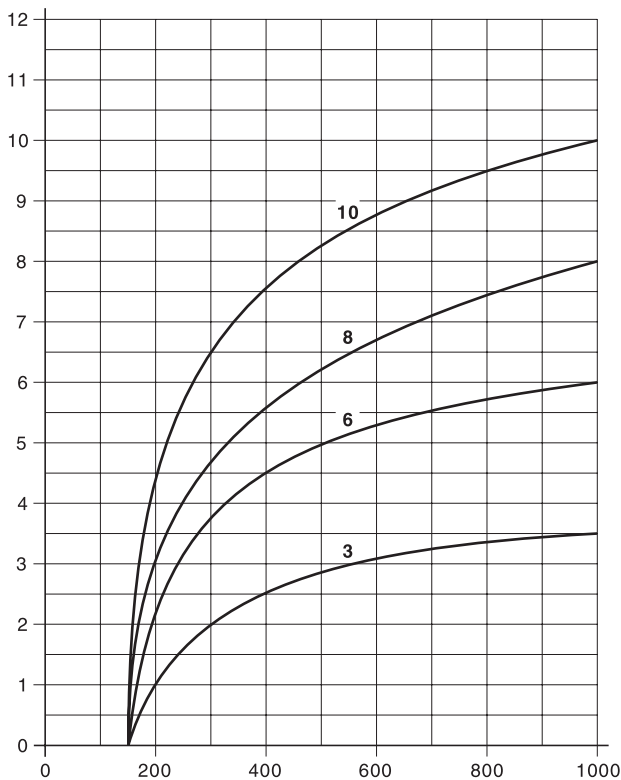

Ansaugdruck • Suction pressure → mbar (abs.)

V-VTE		3	6	8	10	
Saugvermögen Suction capacity	m ³ /h	50 Hz	3,5	6,0	8,0	10
		60 Hz	4,2	7,2	9,6	12
Enddruck Ultimate vacuum	mbar (abs.)	150				
Motorausführung Motor version	3~	50 Hz	200 - 255 / 346 - 440 V			
		60 Hz	200 - 277 / 346 - 480 V			
	1~		230V ± 10% (50 / 60 Hz)			
Motorleistung Motor rating	kW (3~)	50 Hz	0,120	0,25	0,37	0,37
		60 Hz	0,145	0,30	0,44	0,44
	kW (1~)	50 Hz	0,120	0,25	0,35	0,35
		60 Hz	0,145	0,30	0,42	0,42
Stromaufnahme Current drawn	A (3~)	50 Hz	1,12 / 0,71	1,40 / 0,81	2,77 / 1,6	2,77 / 1,6
		60 Hz	1,02 / 0,62	1,6 / 0,9	2,25 / 1,3	2,25 / 1,3
	A (1~)	50 Hz	1,3	2,3	3,4	3,4
		60 Hz	1,4	2,5	3,9	3,9
Drehzahl Speed	min ⁻¹	50 Hz	2700 - 2860			
		60 Hz	3150 - 3380			
Mittlerer Schalldruckpegel Average noise level	dB(A)** ENISO3744	50 Hz	55	57	59	60
		60 Hz	57	59	61	62
Max. Gewicht Max. weight	kg	6,5	7,5	8,0	10,3	

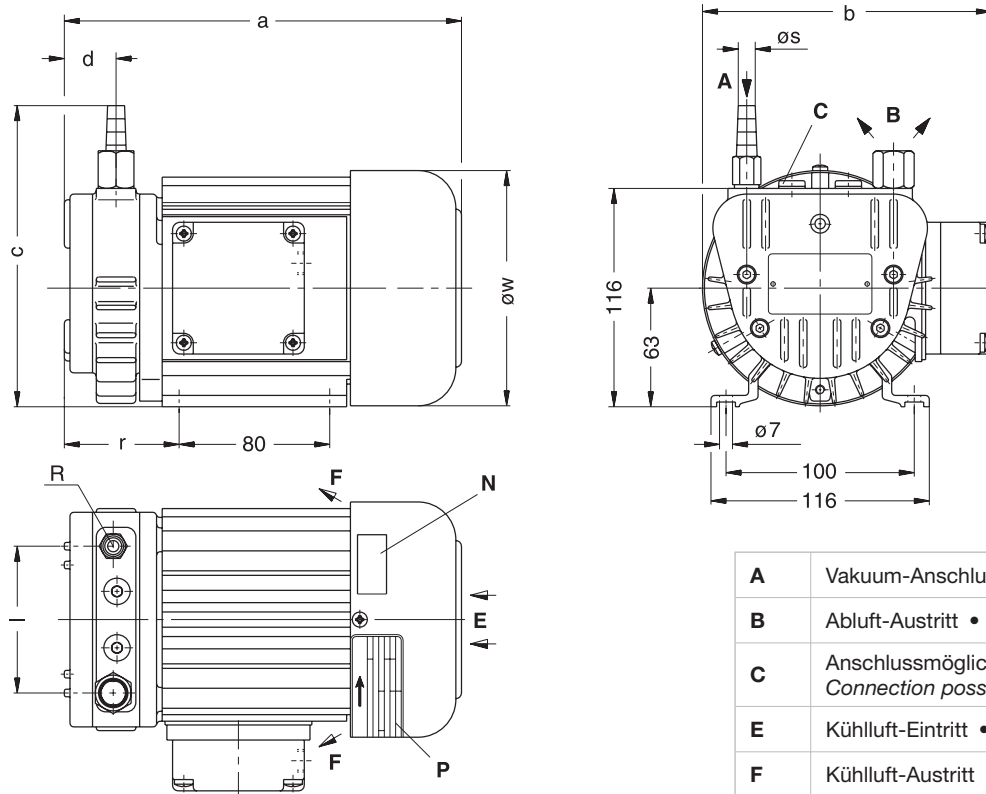

A	Vakuum-Anschluss • Vacuum connection
B	Abluft-Austritt • Exhaust
C	Anschlussmöglichkeit für Vakuum-Regulierventil Connection possibility for vacuum regulating valve
E	Kühlluft-Eintritt • Cooling air entry
F	Kühlluft-Austritt • Cooling air exit
N	Datenschild • Data plate
O	Drehrichtungsschild • Direction of rotation
P	Motordatenschild • Motor name plate

V-VTE	3	6	8	10
a	209	224	249	264
b	156	156	156	156
c	151	156	156	156
d	24	28	27	27
l	78	82	82	82
r	60	75	80	95
øS	8-10	10-12	10-12	11-13
øW	125	125	125	125
R	G 1/8	G 3/8	G 3/8	G 3/8

Zubehör • Accessories

V-VTE		3	6	8	10	
Vakuum-Regulierventil Vacuum regulating valve	ZRV	6/0	6/0	12/0	12/0	
Rückschlagventil Non-return valve	ZRK	6 (03)	12 (03)	12 (03)	12 (03)	
Motorschutzschalter Motor starter	ZMS (3~)	50 Hz	16 / 10	16 / 10	40 / 25	40 / 25
		60 Hz	16 / 10	16 / 10	25 / 16	25 / 16
	ZMS (1~)	50 Hz	16	25	40	40
		60 Hz	16	40	40	40

m³/h* bezogen auf den Zustand im Sauganschluss • refers to suction conditions at inlet connection

Kennlinien, Tabellenangaben (Toleranz ±10%) beziehen sich auf betriebswarme Vakuumpumpen. • Curves, tables content (tolerance ±10%) refer to vacuum pump at normal operating temperature.

Technische Änderungen vorbehalten! • We reserve the right to alter technical information!